

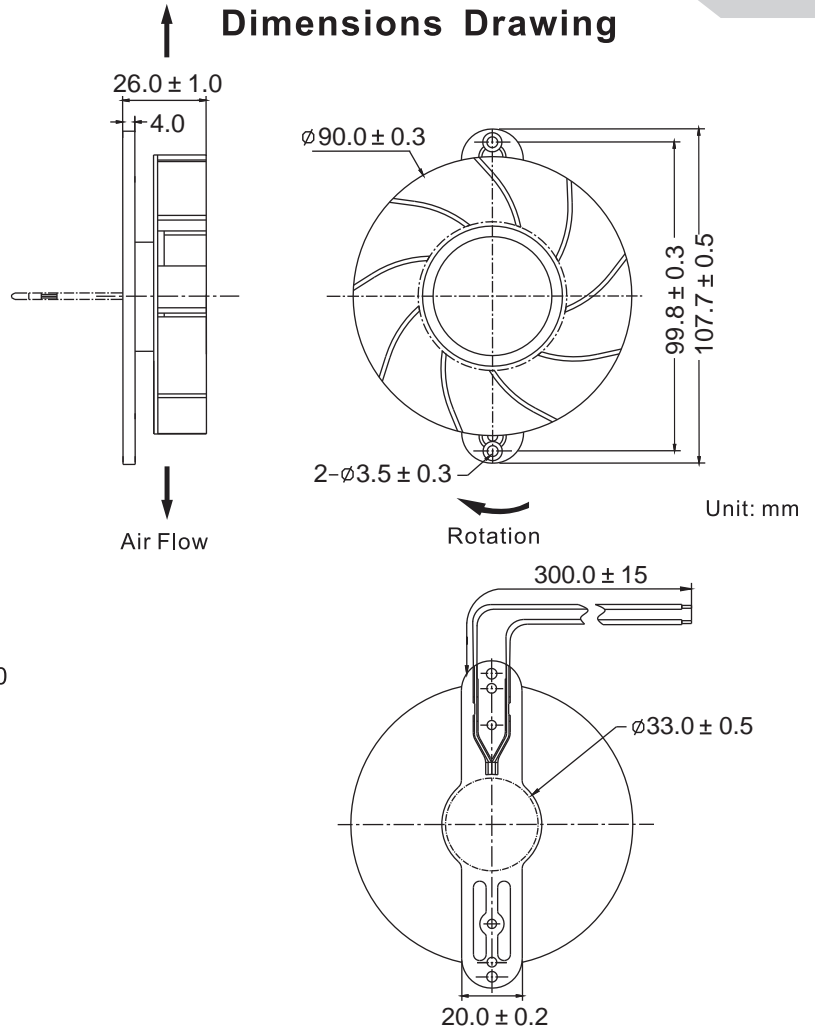

Dimensions Drawing



General Specification

- Frame and Impeller : Thermal Plastic , UL 94V-0
- Lead Wires : UL Type
(+) : Red (-) : Black
- Operation Temperature : -10°C~70°C
35%~85%RH
- Storage Temperature : -40°C~80°C
35%~85%RH
-

Listed Model	Bearing System	Rated Voltage	Operation Voltage	Rated Current	Rated Speed	Air Flow	Air Pressure	Noise Level	Available Features (Optional)				Weight
		VDC	VDC	A	RPM	CFM	mmH ₂ O	dBA	Tachometer Output	Rotation Detector	Thermal Control	Pulse Width Modulation	g
RDH9025SAPF	Sleeve	12	6.0~13.8	0.35	2,500	---	---	38	•	•			82
RDM9025SAPF			6.0~13.8	0.25	2,100	---	---	31	•	•			
RDL9025SAPF			6.0~13.8	0.20	1,800	---	---	27	•	•			
RDH9025SBPF			6.0~13.8	0.35	2,500	---	---	38	•	•			
RDM9025SBPF			6.0~13.8	0.25	2,100	---	---	31	•	•			
RDL9025SBPF			6.0~13.8	0.20	1,800	---	---	27	•	•			

● All readings are typical values at rated voltage.
● Specifications are subjected to change without prior notice.